

SuperGrid-2 Workshop

University of Illinois at Urbana-Champaign (UIUC)

October 25-27, 2004

Bob Lasseter

University of Wisconsin-Madison



Superconducting Network

System:

Low voltage high current DC superconducting network
(generation>DC>distribution)

Issues

- Complexity of System control (100s of sources and 100,000s loads)
- Current control

References:

Johnson,B.K., R.H. Lasseter, F.L. Alvarado, D.M. Divan, H. Singh, M.C. Chandorkar, and R. Adapa, "High-Temperature Superconducting dc Networks", IEEE Transactions On Applied Superconductivity, Vol. 4, No.3, pp.115-120, September 1994.

Tang, W and R.H.Lasseter, "An LVDC Industrial Power Distribution System without Central Control Unit," PECS , Ireland, June 2000.



DC Transmission Systems

Traditional:

- Multi Terminal HVDC

Superconducting

- Networking issues
- Current control

Traditional Mult-terminal HVDC

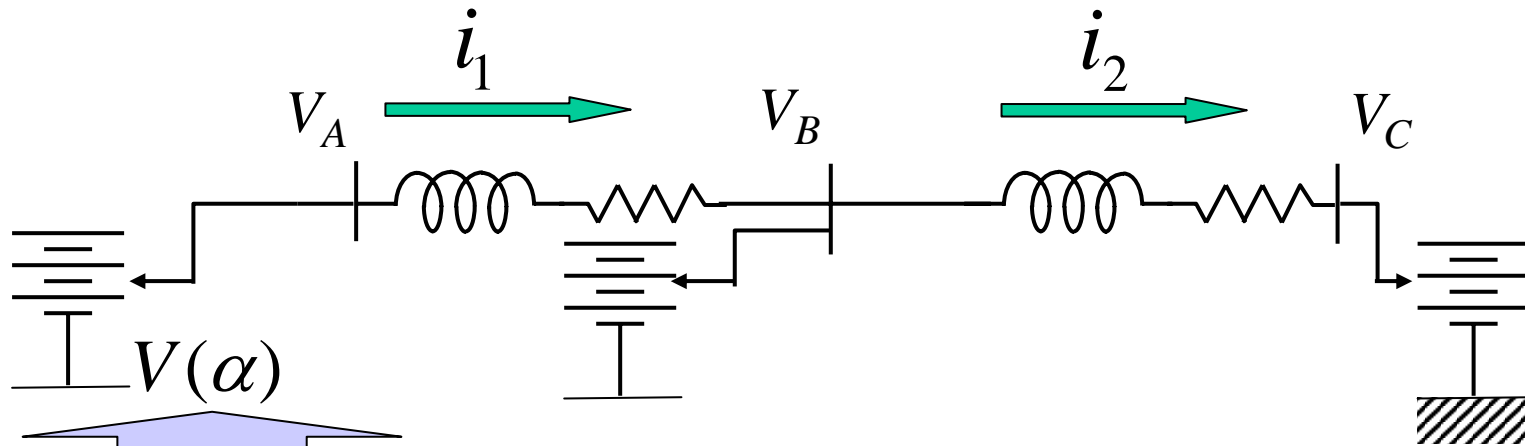

Thyristor Controlled Rectifier

$$\langle V_{dc} \rangle = V(\alpha) - \frac{3}{\pi} X_{ac} I_{dc}$$

$V_A, V_B, \& V_C$ Control currents



Traditional HVDC “Net”

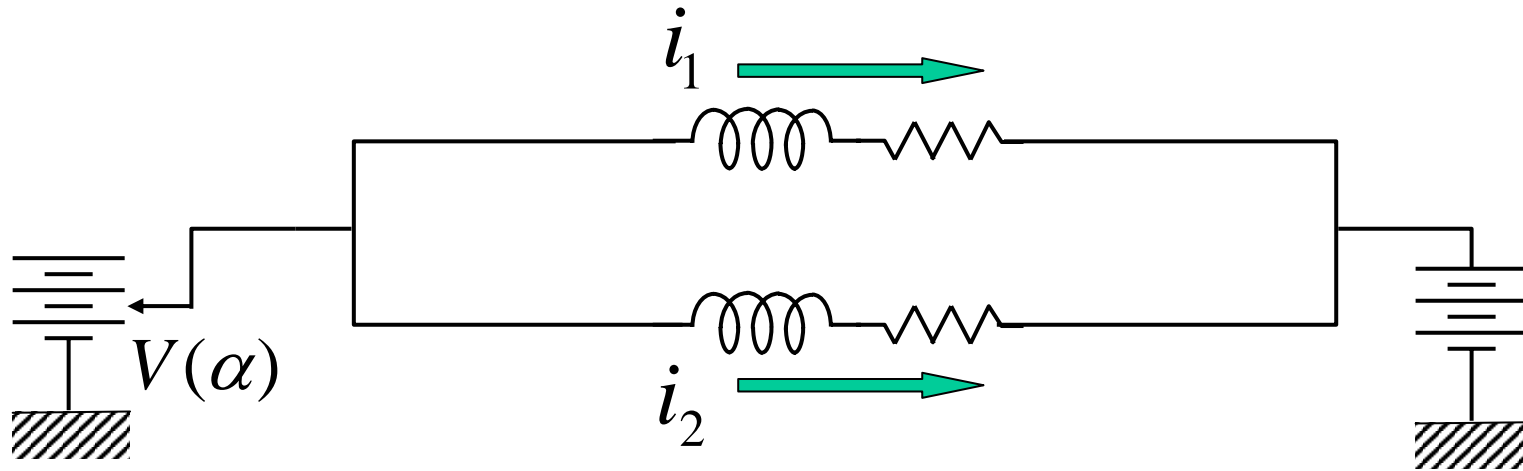

i_1 & i_2 are a function of R_1 & R_2

Can not independently control currents

Control of Current: dc/dc converter

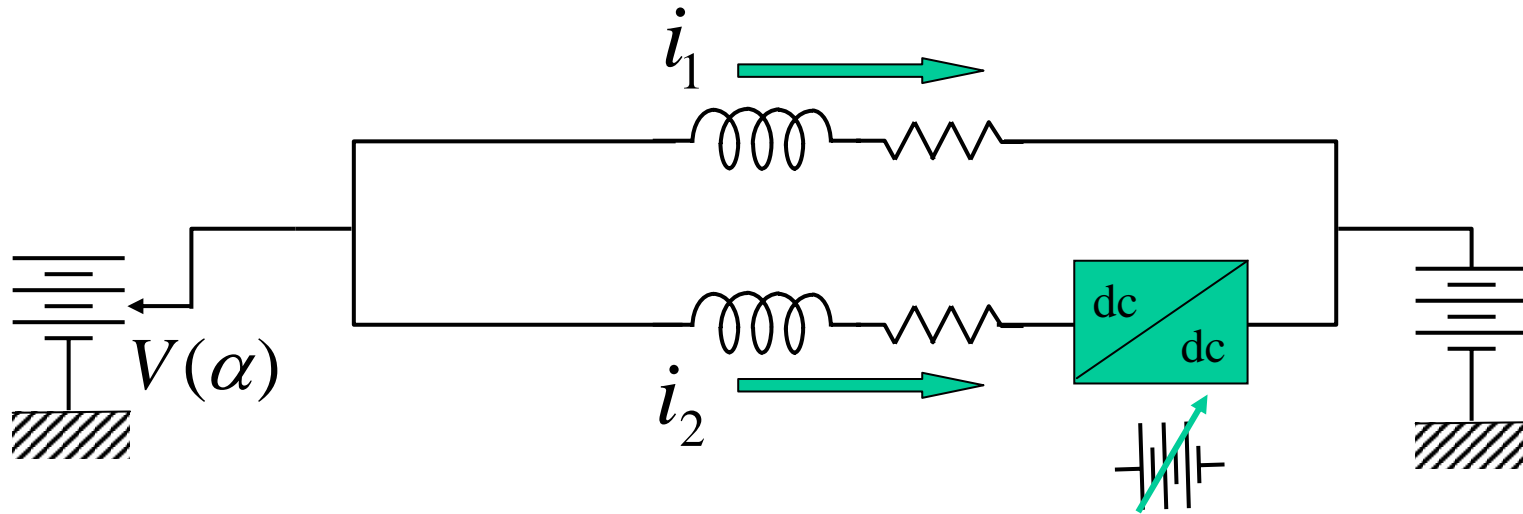

- High current in the dc/dc converter

Current levels in superconductors

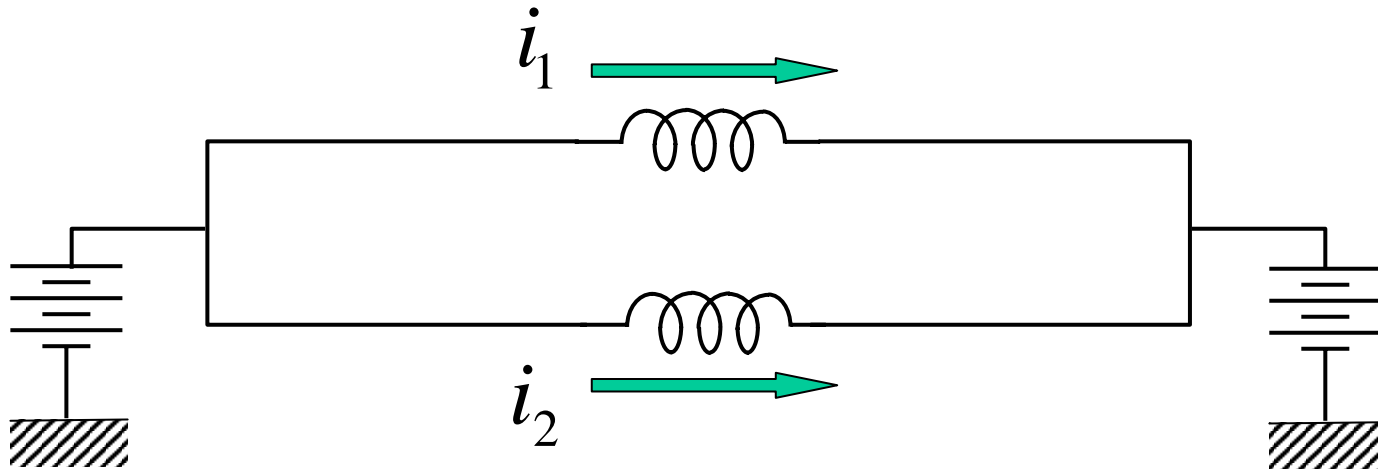

- In steady state there is a single dc voltage across the system
- Current flow is a function of ΔV over time and the line inductance.



Current levels in superconductors

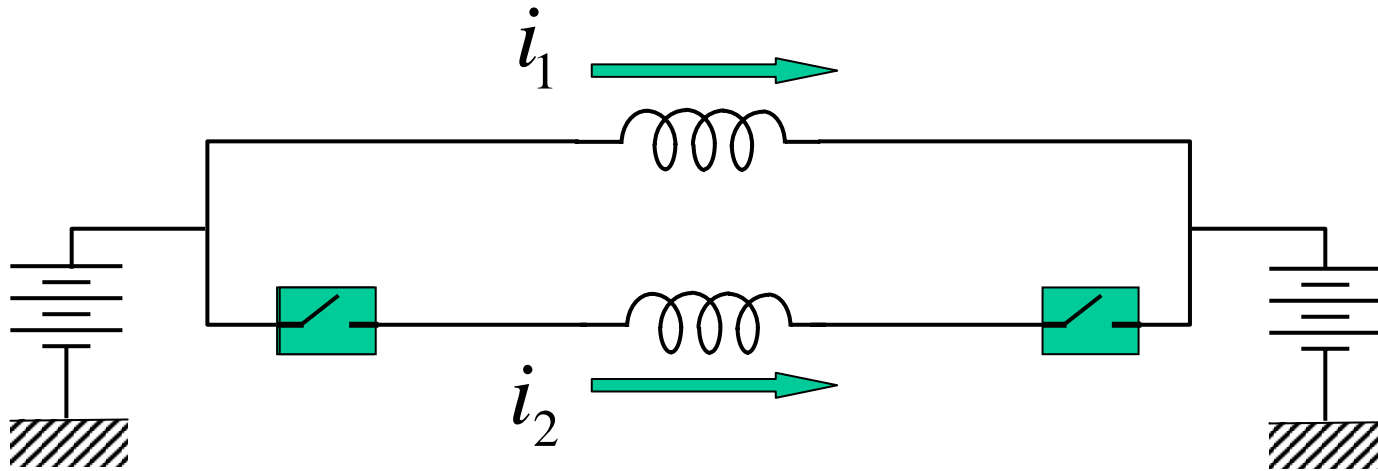

When line 2 is inserted no current will flow

Current levels in superconductors

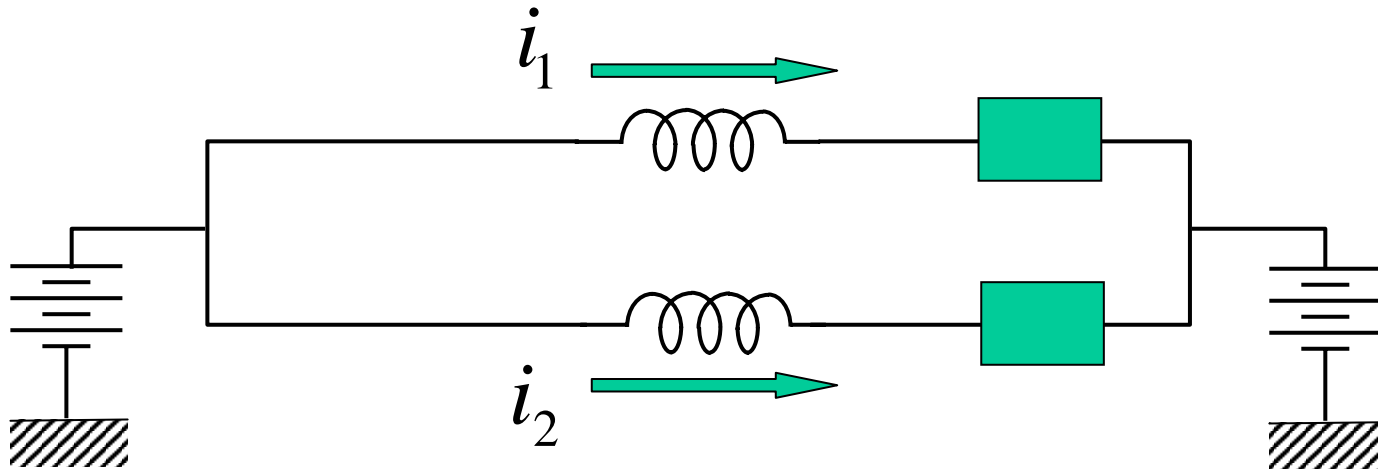

DC/DC Converter: High current and zero ΔV in SS

Superconductor Current steering*: Slow to recover

References:

*Johnson, B.K., R.H. Lasseter, F.L. Alvarado, and R. Adapa, "Superconducting Current Transfer Devices for Use with a Superconducting LVdc Mesh", IEEE Transactions on Applied Superconductivity, Vol. 4, No. 4, pp. 216-222, December 1994



Superconducting Cable

System Issues

- Difficult to create networks
- + No load dependent voltage drop

Can create a superconductor ring and use the voltage for control.



Ring SuperGrid

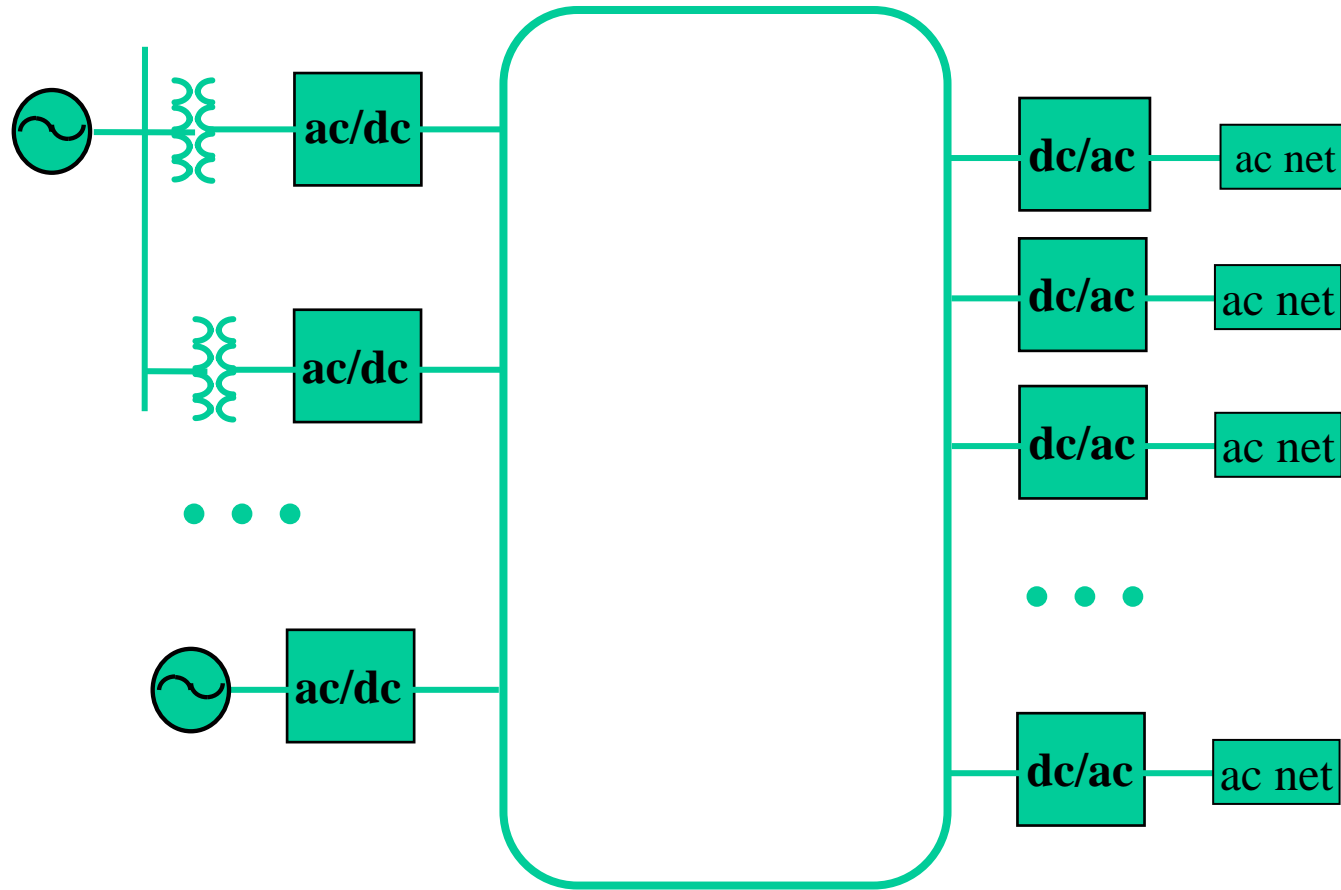

Rectifiers control
DC voltages based on current

Inverters control DC currents
through control of ac voltage

Power Dispatch on dc voltage

Thyristor Controlled Rectifier

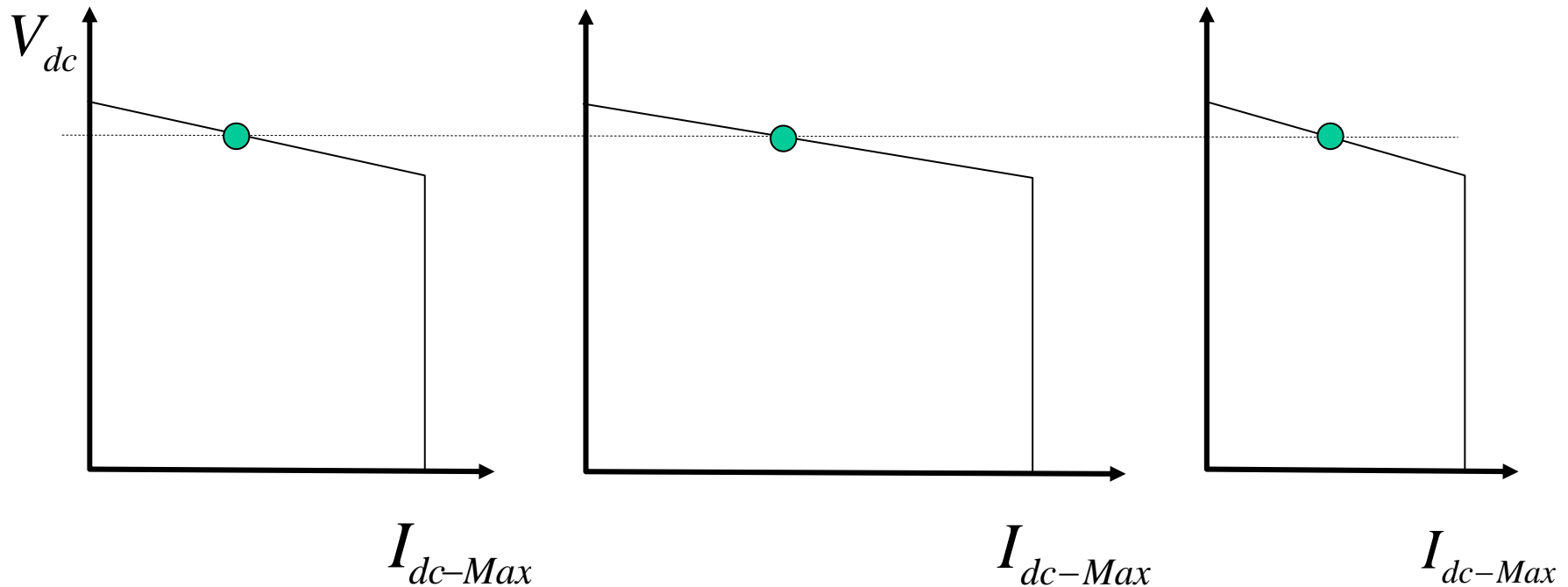

$$\langle V_{dc} \rangle = V(\alpha) - \frac{3}{\pi} X_{ac} I_{dc}$$

Power Dispatch on dc voltage

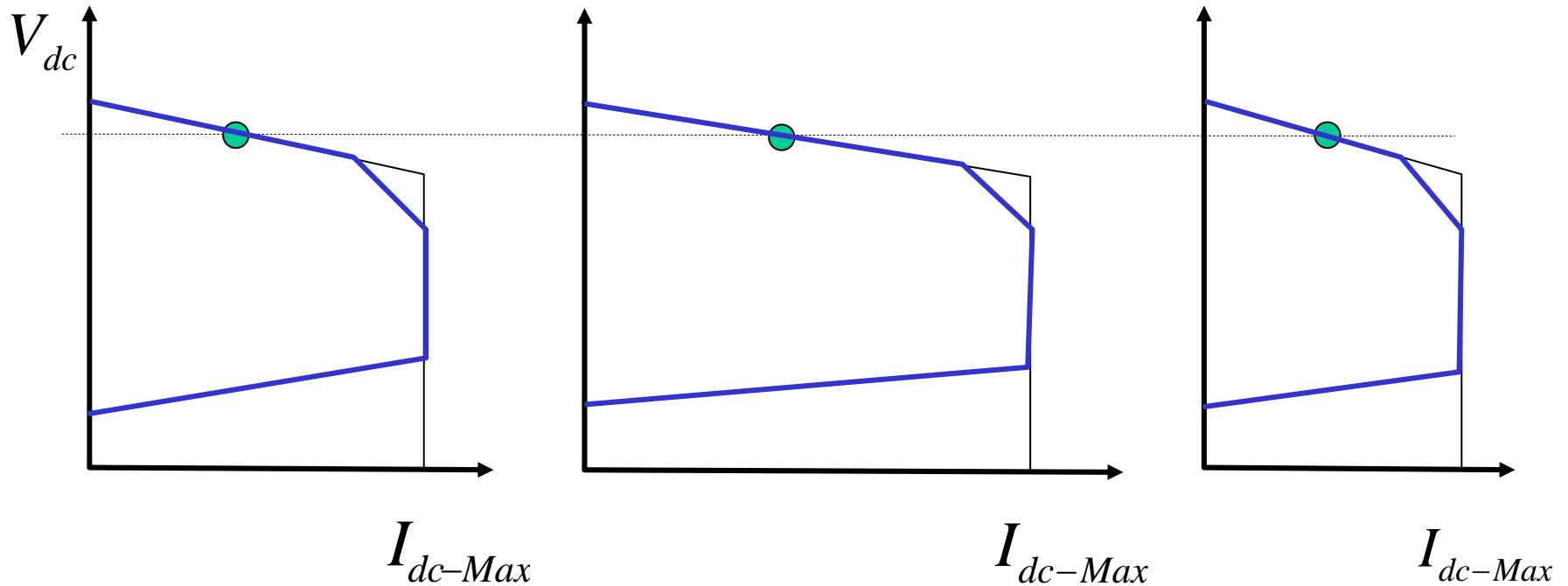

Power Dispatch on dc voltage

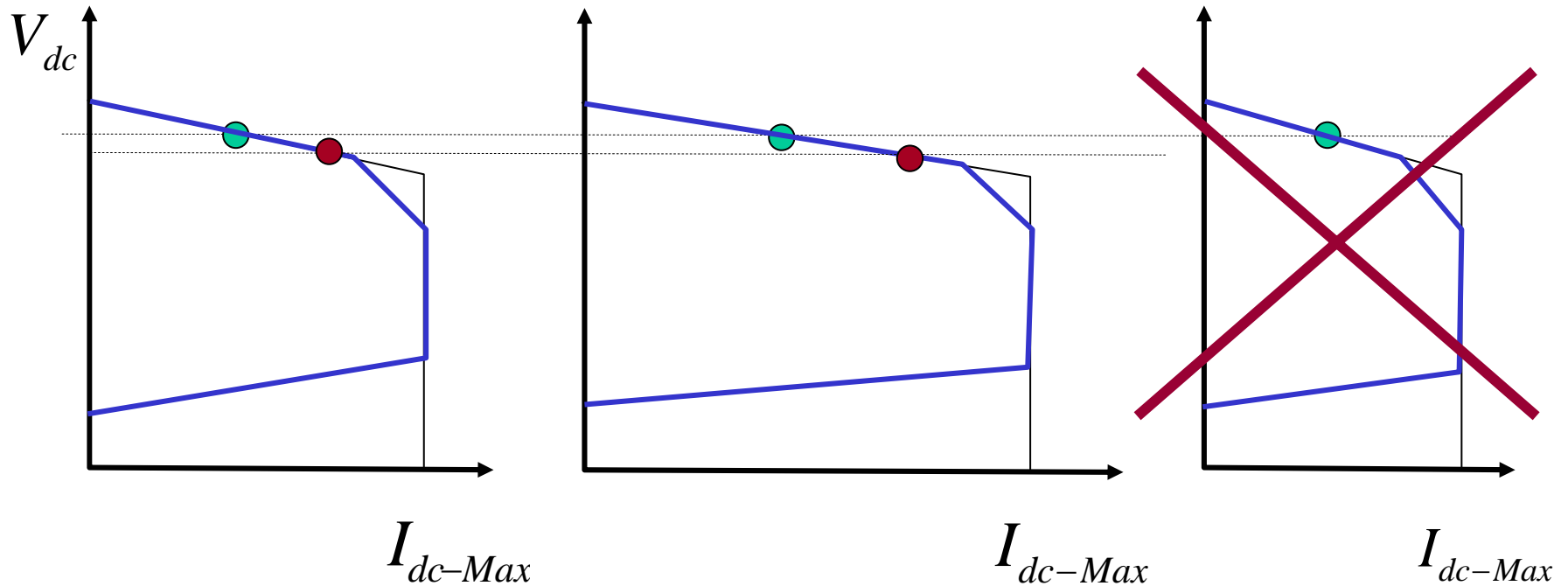

DC voltage with loss of one Rectifier

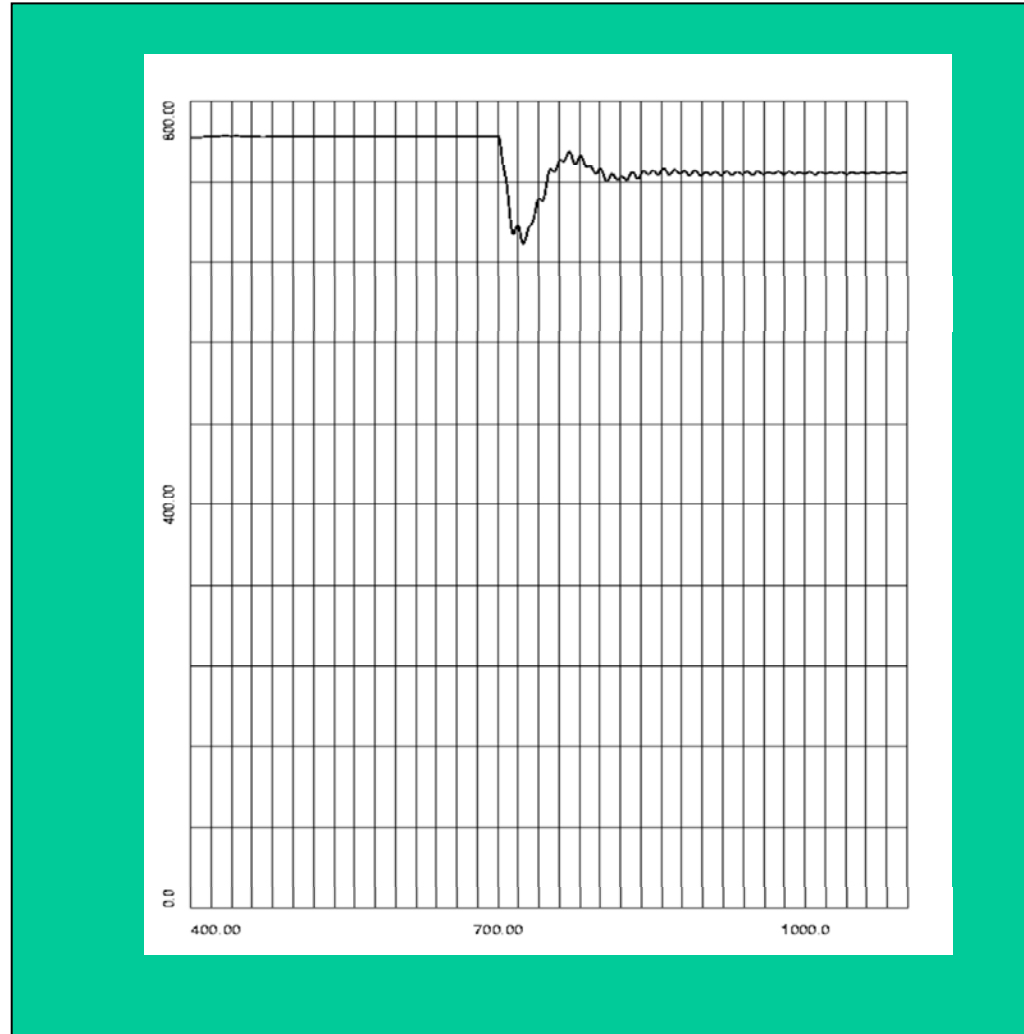

Distributed Control

Rectifiers

- Share load
- Independent of number

Inverters

- Provides stable ac voltage to the load
- Automatic load shedding

Coordination is achieved through dc voltage

Reference:

Tang, W and R.H.Lasseter, "An LVDC Industrial Power Distribution System without Central Control Unit," PESC , Ireland, June 2000.



Single system voltage used for load tracking control

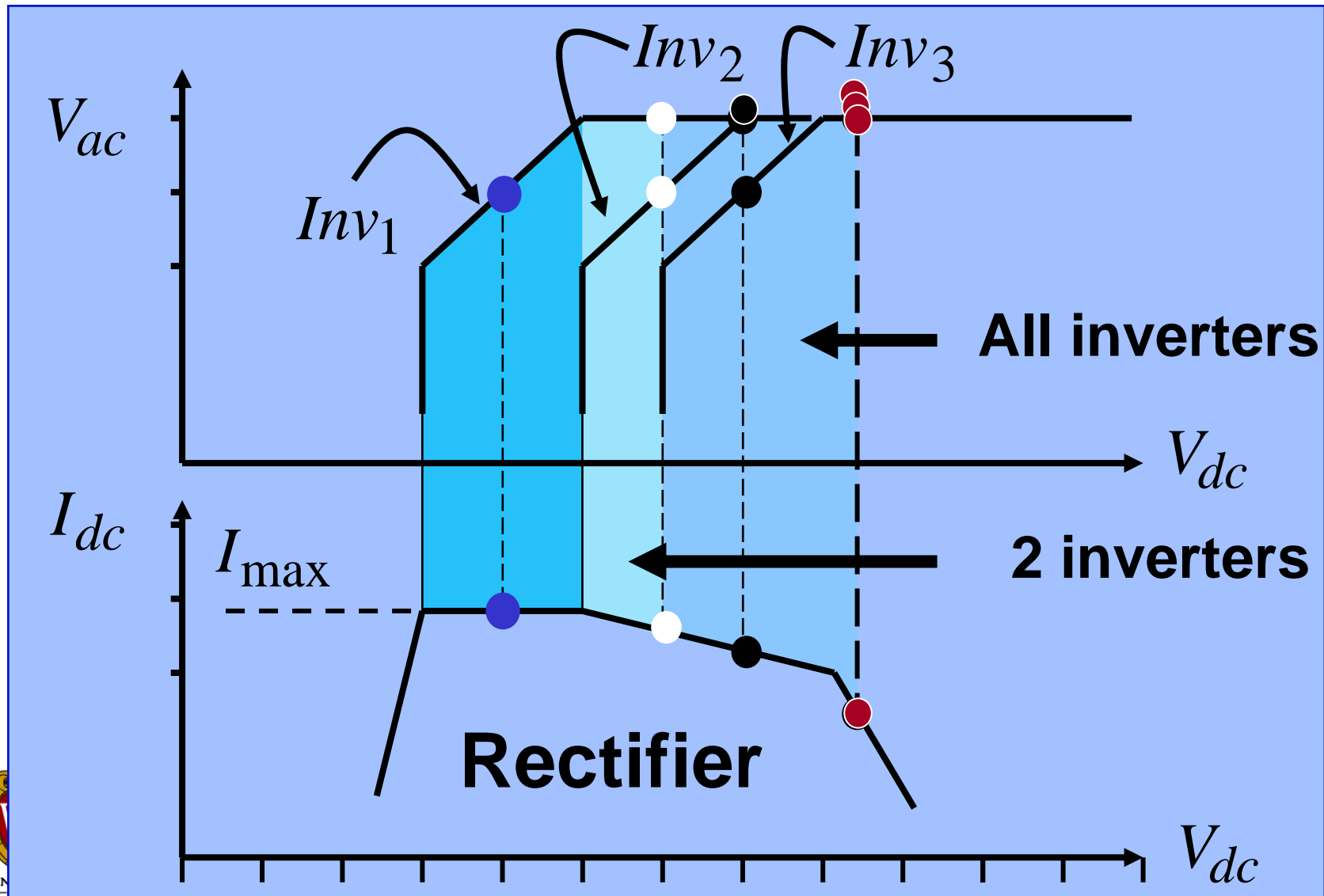

Research Issues

- Proof of principle of the “ring concept” with voltage control
- Current steering methods
- Fault clearing
- Hydrogen only grid- Local DER for generation.